







TECTON

MANUAL

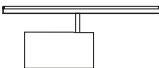
| | | | |
|---|------------------------------------|--|----|
|  | 1. Trunking | Trunking | 4 |
| | | Mountings | 6 |
| | | In-feed and out-feed options | 7 |
| | | Range | 8 |
| | | Node connector | 9 |
|  | 2. Continuous-row luminaire | TECTON C with split-lens technology | 14 |
| | | TECTON MIREL with MIREL lens optic | 23 |
| | | TECTON MPO with micro-prismatic optic | 24 |
| | | TECTON BASIC with diffuser optic | 25 |
|  | 3. Industrial luminaires | CRAFT II high-bay luminaire | 27 |
| | | PERLUCE moisture-proof luminaire | 27 |
| | | AMPHIBIA moisture-proof luminaire | 27 |
|  | 4. Spotlights | PANOS infinity pendant luminaire | 29 |
| | | INTRO spotlight | 29 |
| | | VIVO II spotlight | 29 |
|  | 5. Office luminaires | ECOS II luminaire for micro-pyramidal optic | 31 |
| | | MELLOW LIGHT luminaire for office applications | 31 |
| | | LINCOR surface-mounted luminaire for office applications | 31 |
|  | 6. Emergency lighting | RESCLITE PRO emergency luminaire | 32 |
| | | PURESIGN 150 escape-sign luminaire | 33 |
| | | CROSSIGN 110/160 escape-sign luminaire | 33 |
| | | ECOSIGN 160 escape-sign luminaire | 33 |
| | | Monitoring and supply systems | 34 |
|  | 7. Lighting management | Sensors | 36 |
| | | Integration in TECTON systems | 38 |
| | Installation | Save time and money with TECTON | 40 |
| | TECTON IP20 system overview | Product family overview | 42 |
| | TECTON IP64/IP54 | Resistant to dust and spray water | 44 |
| | Project testimonials | Practical examples of TECTON's expert solutions | 46 |

TECTON TRUNKING

Optional cable duct

- Additional cable duct for running cable on rear side
- No adverse effect on trunking suspension

Cable duct

Additional cable can be accommodated if required

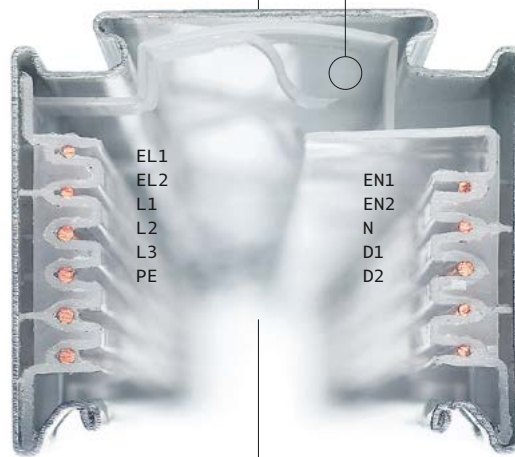

1 : 1 scale

Butt-joint connectors for quick and easy installation without any additional components

- Complete flexibility as power can be tapped into over the entire length of the track
- Preassembled connector makes it possible to install the continuous row without having to use any other tools or equipment
- Electrical and mechanical connection with a simple flick of the wrist

READY FOR FUTURE TECHNOLOGIES

Integrating new technologies in an existing system? Not a problem with TECTON. With its 11 poles, the trunking not only provides a basis for general lighting, but also allows safety lighting and lighting controls to be integrated seamlessly. It offers 100 % flexibility along the entire length of the continuous row. As each trunking also has two control lines and two independent emergency lighting circuits in addition to five mains lines, TECTON is always ready for future

interfaces: five or even ten years after initial installation, state-of-the-art luminaire, sensor and emergency lighting modules can be retrofitted without having to replace the entire system. The TECTON trunking makes integration effortless while remaining unchanged as a functional basis, making the continuous-row lighting system sustainable, cost-efficient and future-proof.

5 connections for power supply (5x2.5mm²)

- Load sharing allows triple continuous-row length
- Separately switchable circuits for extremely easy light control in triple circuit

4 poles for two independent emergency lighting circuits (4x1.5mm²)

- Two independent emergency lighting circuits allow optimal integration of emergency lighting into general lighting
- High degree of design reliability, flexibility and adaptability after commissioning

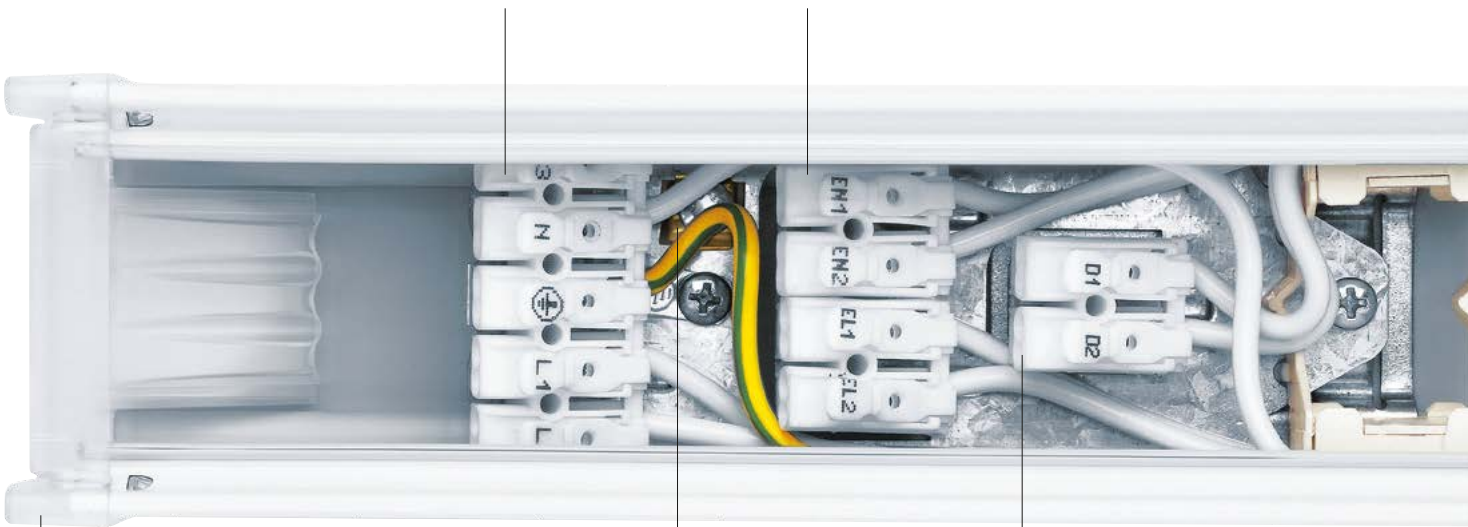

TECTON TE feed-in | 1:1 scale

2. terminal for conductor

An additional terminal offers the chance to connect more conductors

2 control lines with DALI control signal for brightness control (2x1.5mm²)

- Efficient, flexible, customised lighting for industrial and commercial buildings
- Purposefully staged lighting scenes in shops and retail areas
- Intelligent lighting management system reports all faults (e.g. electronic ballast or lamp failure)

Surface in white, silver or black

Roll-formed sheet steel with option of white, silver or black polyester resin enamel finish



white



silver



black

TOOL-FREE INSTALLATION

One of the TECTON continuous-row lighting system's most distinctive features is that all its components can be installed without the need for tools. Thanks to a unique, preassembled connector, the trunkings can be connected mechanically and electrically in no time. Luminaires and sensors simply click into place and can be repositioned easily.

TIME-SAVING INSTALLATION

Ease of use equals savings on installation time and costs. The reduced number of work steps associated with the TECTON continuous-row lighting system represents time savings of up to 55 per cent compared with similar solutions, according to an independent investigation of eight LED continuous-row lighting systems (15 m) by Refaconsult GmbH.

FIXING OPTIONS

Cord suspension using Clix mechanism

Nothing is easier than fixing TECTON trunking. An ingeniously functional mounting bracket provides a clever link between the wall or ceiling and the trunking. The cord suspension can be fixed to the trunking without the use of any tool by exerting slight pressure, and it can also be moved as required. Pendant height adjustment is also entirely tool-free.



TECTON Cord suspension

Suspension spans

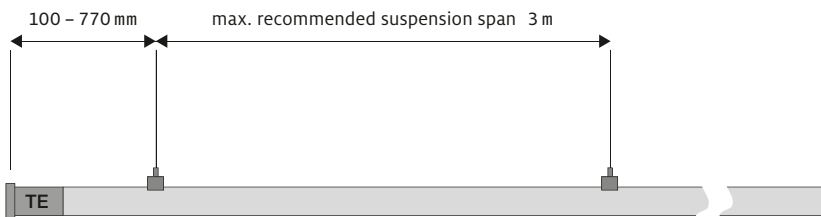

A maximum suspension span of 3 m ensures quick and easy installation with fewer suspension points.

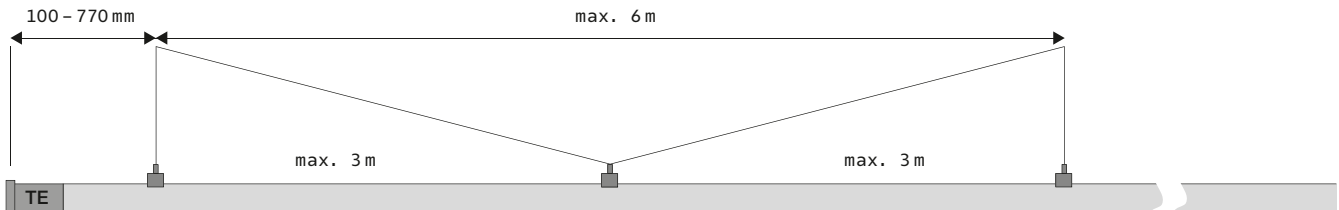

For those special cases in which the ceiling construction does not permit suspension spans of 3 metres, the M suspension kit enables extended spacings of up to 6 metres between suspension points.

May be installed by qualified personnel only.

POSSIBLE FEED-IN AND FEED-OUT POINTS

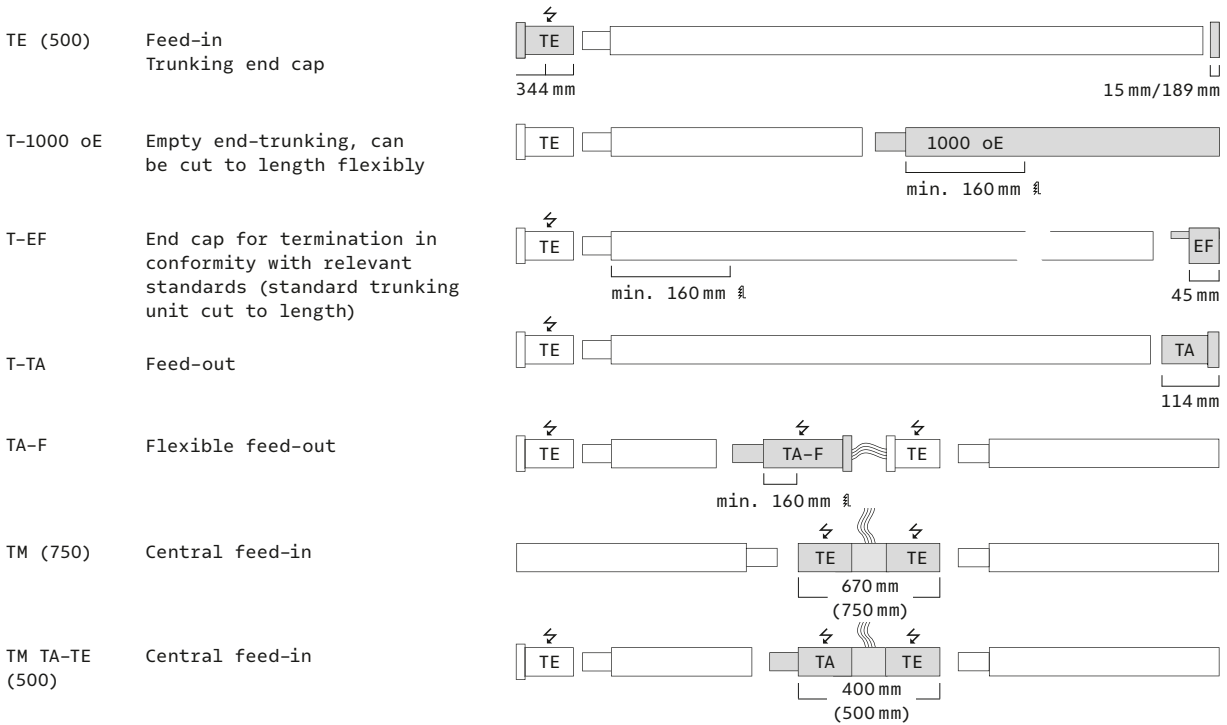

Possible feed-in and feed-out points

TECTON provides a wide variety of possible feed-in and feed-out points to cope with customer-specific requirements and conditions. An additional feed-in point is recommended for continuous-row systems which are longer than 50 m. TECTON central feed-ins are perfect for this purpose, especially since they do not disrupt the visual continuity of a continuous-row system.

Note: TECTON LED battens in lengths of 1000 mm, 1500 mm and 2000 mm fully conceal the input/output feeder (no emergency luminaires). This is not possible with spotlights, sensors and RESCLITE emergency luminaires due to the close rotary toggle spacing.

WIDE RANGE OF TRUNKING OPTIONS

Wide range of trunking options

Design and implementation are made easy thanks to gradation in 0.5m increments.

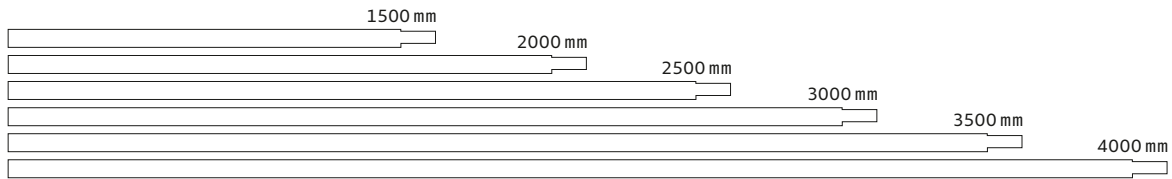

Trunking kit

Pre-assembled trunking unit which comprises T-trunking and TE electrical feed with end caps and protective covers.

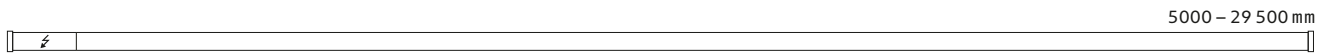

Individual trunking units in four lengths

This means that individual luminaires have the same appearance as the continuous-row system.

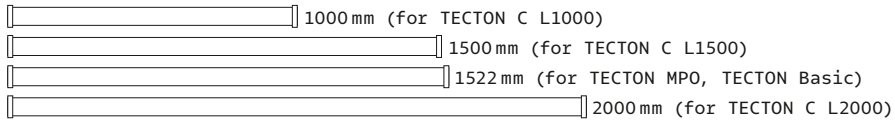

Blank end trunking

Can be cut to length by the customer, at the end of the continuous-row system (1000oE).



NODE CONNECTOR

Using various node connectors, the TECTON continuous-row lighting system can be assembled and combined in a myriad of variants, fully meeting the respective requirements in terms of design and lighting technology. TECTON L-, T-, X- and flexible connectors open up many different options for creative design using light. Thus, the structures themselves become integral parts of the interior design. The electrical engineer will define the wiring sequence via the node connectors on site, depending on the application requirements.



VIEW FROM ABOVE

L – node connector

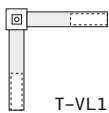

T-VL1



T-VL4

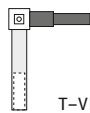

T-VL2

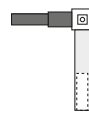

T-VL3

- ⊗ Fixing point
- Electric feed
- Feed-out

T – node connector

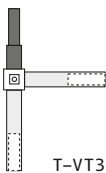

T-VT3

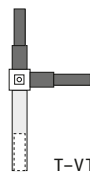

T-VT4

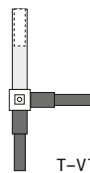

T-VT2

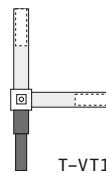

T-VT1

X – node connector

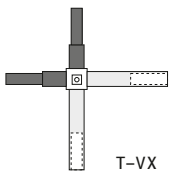

T-VX

FLEX – flexible connector

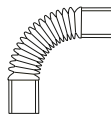

Calculating axial dimensions with node connectors

The axial dimension can be calculated very easily: two connectors together give 0.5 m. The trunking units are also provided in increments of 0.5 m. Therefore the axial dimension is always the trunking length plus 0.5 m.

Example: Axial dimension (mm) = length of trunking + 500 mm
Axial dimension (135 mm + 365 mm = 500 mm) + trunking T 1500 bis T 4000

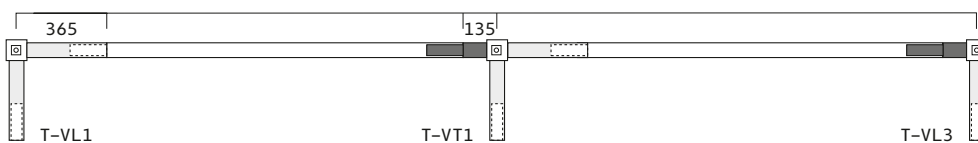



INSTALLATION EXAMPLES

It's not easy to describe in a single brochure just how many different combinations the innovative TECTON continuous-row lighting system makes possible. The four examples of basic shapes therefore only provide a schematic overview of the configuration options with TECTON node connectors.

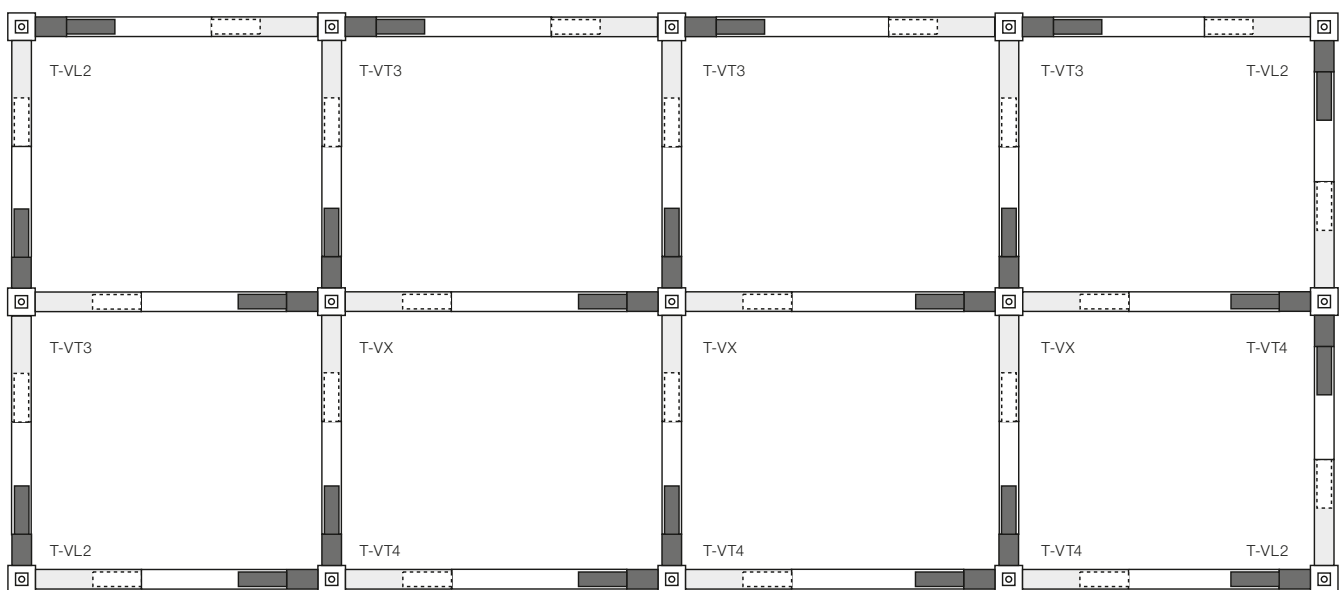
Eight-part closed frame



| Quantity | Name | Order no. white | Order no. silver | Order no. black |
|----------|-------------------------------|--------------------|---------------------|--------------------|
| 4 | TECTON T-VL2 L-node connector | 22 157 274 | 22 157 282 | 22 171 306 |
| 4 | TECTON T-VT3 T-node connector | 22 157 279 | 22 157 287 | 22 171 311 |
| 4 | TECTON T-VT4 T-node connector | 22 157 280 | 22 157 288 | 22 171 312 |
| 3 | TECTON T-VX X-node connector | 22 157 272 | 22 157 289 | 22 171 313 |

View from above:
 Fixing point
 Electric feed
 Feed-out

One-piece closed frame

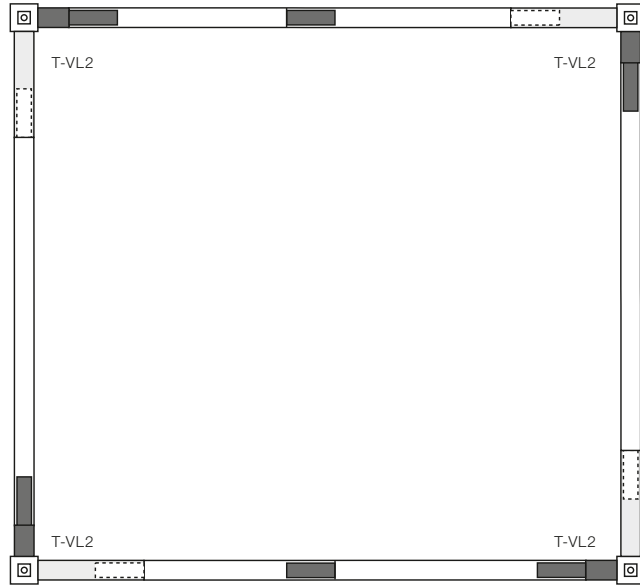

| Quantity | Name | Order no. white | Order no. silver | Order no. black |
|----------|-------------------------------|--------------------|---------------------|--------------------|
| 1 | TECTON T-VL2 L-node connector | 22 157 274 | 22 157 282 | 22 171 306 |

View from above:
 □ Fixing point
 □ Electric feed
 ■ Feed-out

Two-piece open frame

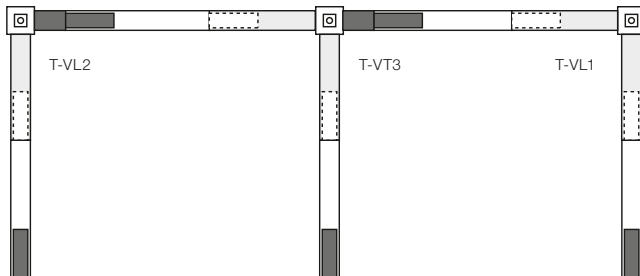



| Quantity | Name | Order no. white | Order no. silver | Order no. black |
|----------|-------------------------------|--------------------|---------------------|--------------------|
| 1 | TECTON T-VL2 L-node connector | 22 157 274 | 22 157 282 | 22 171 306 |
| 1 | TECTON T-VT3 T-node connector | 22 157 279 | 22 157 287 | 22 171 311 |
| 1 | TECTON T-VL1 L-node connector | 22 157 273 | 22 157 281 | 22 171 305 |

View from above:
 □ Fixing point
 □ Electric feed
 ■ Feed-out

One-piece open frame



| Quantity | Name | Order no. | Order no. | Order no. |
|----------|-------------------------------|------------|------------|------------|
| | | white | silver | black |
| 1 | TECTON T-VL2 L-node connector | 22 157 274 | 22 157 282 | 22 171 306 |
| 1 | TECTON T-VL1 T-node connector | 22 157 273 | 22 157 281 | 22 171 305 |

View from above:
 Fixing point
 Electric feed
 Feed-out

One-piece closed frame

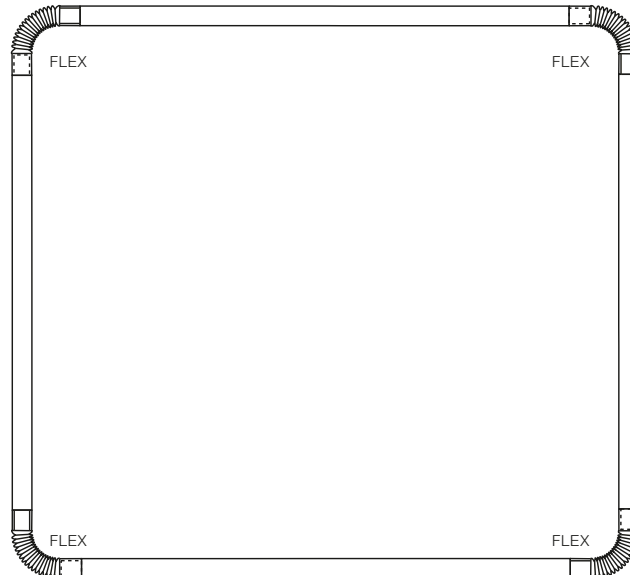

| Quantity | Name | Order no. |
|----------|------------------------------|------------|
| 4 | TECTON V FLEX FLEX connector | 22 166 765 |

TECTON CONTINUOUS-ROW LUMINAIRE

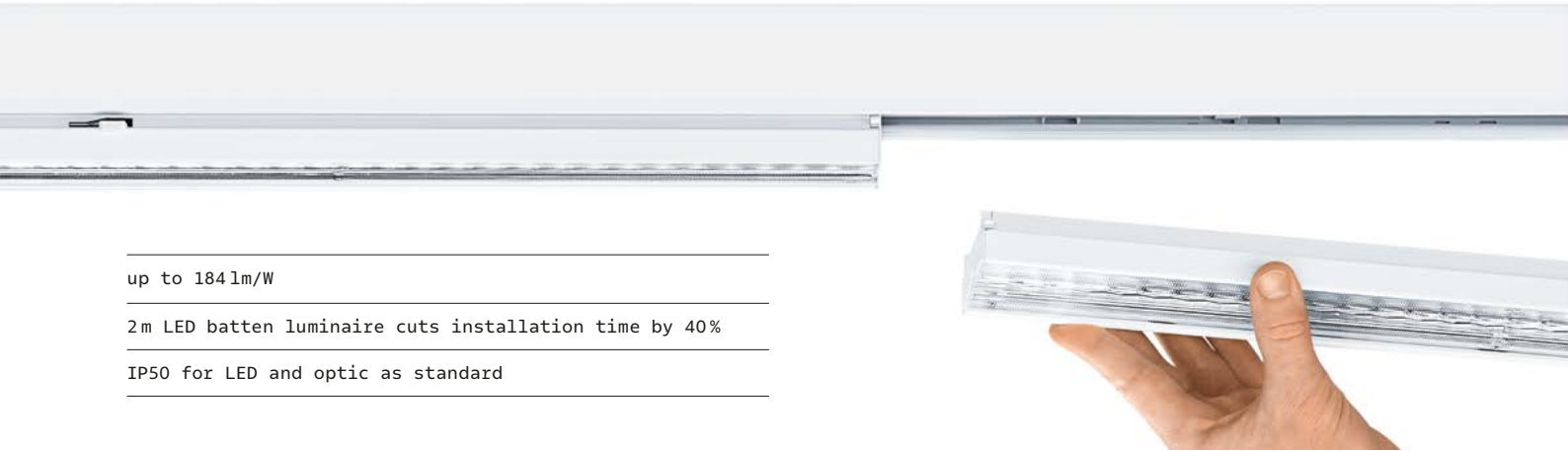

up to 184 lm/W

2m LED batten luminaire cuts installation time by 40%

IP50 for LED and optic as standard

Module lengths

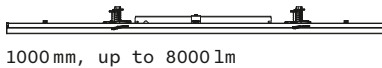
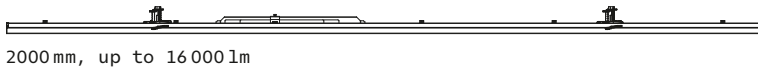

TECTON C WITH SPLIT-LENS TECHNOLOGY

Linear lighting: TECTON is a visual and functional unit. Compact and yet versatile, the linear luminaire emits pure calmness. This continuous-row system is free from joints, forming unbroken light lines that traverse the room. Pre-assembled end-caps reduce the number of components, supporting a solution that is both seamless and quick to install. With a luminaire efficiency of up to 184 lumens per watt, TECTON also offers key economic benefits. Less maintenance work means fewer interruptions and reduced costs thanks to lower energy consumption. In addition, TECTON has an optimal colour rendering index of Ra 80 and an excellent service life – so that even after 100 000 hours of operation, 95 percent of the initial luminous flux will still be achieved.

Design TECTON: Zumtobel

No chance for dust and dirt

The overlapping TECTON C lenses and end caps guarantee an IP50 degree of protection for the LED and optical compartments. The result: the LED compartment is protected effectively against contamination. An accelerated reduction in luminous flux over the operating time is prevented.

A wide range of 'clip-on' lighting effects

The small, inconspicuous add-on clip has a major impact on the lighting effect of the TECTON C. Customised reflectors enable completely new beam characteristics – and expand the design spectrum of TECTON even further. Installation is extremely easy: one 'clip' and the reflector is on.

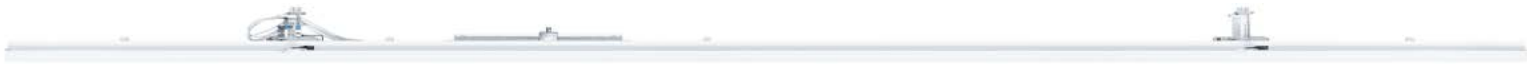

up to 40% shorter installation times

up to 25% fewer individual luminaires

luminaire luminous flux levels of up to 16000lm

Example of a 24m continuous-row luminaire

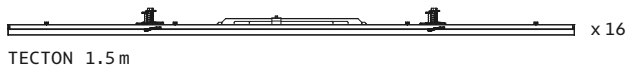

Lower investment and quicker installation: as compared to conventional continuous-row luminaires with a length of 1.5m, the number of luminaires required when using 2m continuous-row luminaires is reduced by some 25 per cent. Mounting can be accelerated by a full 40 per cent.

2 M CONTINUOUS-ROW LUMINAIRES

Regardless of conventional lamp lengths, TECTON C is now available as a 2 m continuous-row luminaire. This reduces both the number of luminaires and the amount of work needed to install them. As compared to continuous-row luminaires with a length of 1.5 m, the new 2 m continuous-row luminaire also means less individual packaging and fewer parts at the installation site. Nevertheless, the 2 m unit comes with all the advantages of the conventional length: the lightweight continuous-row luminaire can still be mounted by one person.

An extra-special continuous row. For added sustainability

TECTON C also offers more than traditional luminaires in terms of continuous-row length, with the 2-metre model offering more benefits than the 1.5-metre variant. As around 25 per cent fewer luminaires are required, installation time can be reduced by up to 40 per cent compared with shorter continuous-row luminaires. Thanks to its low weight, the 2-metre version can be installed by a single installer using the plug & play principle. And the long version of the TECTON also benefits the environment as there is less packaging waste and fewer assembly parts are stored on the construction site.

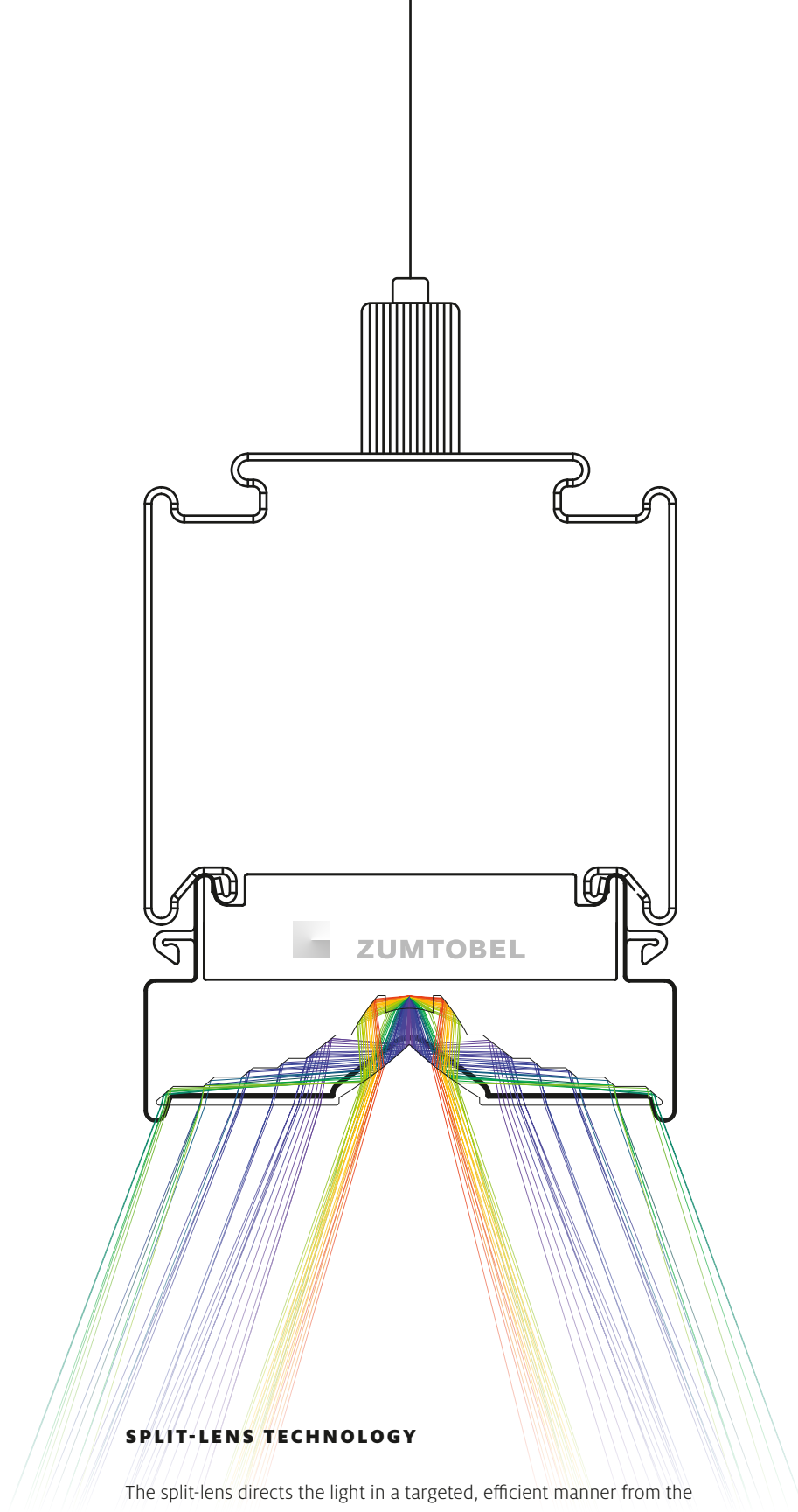

SPLIT-LENS TECHNOLOGY

The split-lens directs the light in a targeted, efficient manner from the centre to the lateral areas. Accordingly, the lighting pressure in the middle is reduced, and the luminaire causes much less glare – without any negative effects on the light distribution curve. With the split-lens concept, all known beam patterns can be realised. The position of the LED remains visible, but in contrast to conventional lenses, the luminaire surface can be extended to the entire width, thus clearly gaining in homogeneity.

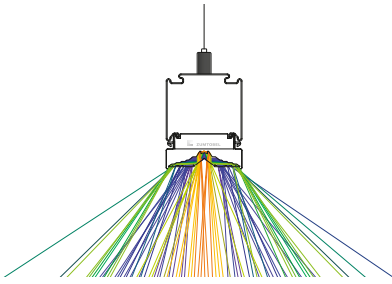

Wide Beam

The Wide Beam optic is equally suitable for handling decorative as well as technical tasks. Its medium-wide light distribution is ideal for lighting shelf surfaces and aisle zones. It also illuminates surfaces without shelves, e.g. manufacturing areas, uniformly.

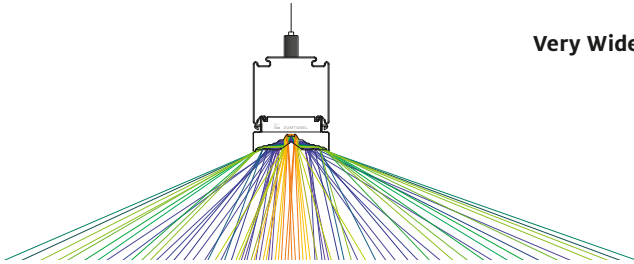

Very Wide Beam

A milestone in the lighting of open spaces: never before have industrial production areas, logistics packing stations or vast retail spaces for seasonal and promotional goods been illuminated with so few luminaires. And with the best quality of light. Despite the high luminous flux, the perceived glare is very low.



Narrow Beam

Specially developed for use in industrial and engineering applications, the Narrow Beam optic ensures efficient, uniform illumination of the vertical fronts of shelving. With a maximum mounting height of around 18 m, it easily copes with medium and large room heights.

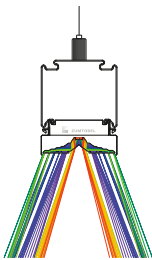

Shelf Beam

The Shelf Beam optic really comes into its own in presentation applications and retail spaces. Its symmetrical light distribution focuses on shelf surfaces; aisle zones are not as brightly lit. This way, customers' attention is directed to the goods that are on display.

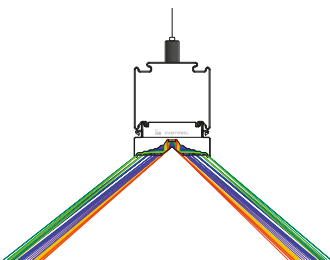

Wide Shelf Beam

An excellent combination of first-class light that is perfectly focused on the goods for the retail food sector: the wide, double asymmetrical light distribution is tailor-made for any retail spaces in which the shelves are far apart or the ceiling height is very low.

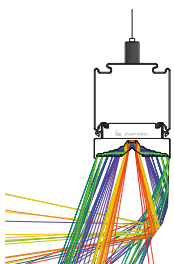

Wallwasher

The wallwasher's asymmetric light distribution is specially designed for presentation and retail areas where there are one-sided shelf surfaces. An unobtrusive reflector that can be clicked into place quickly and without any tools presents goods in the right light.

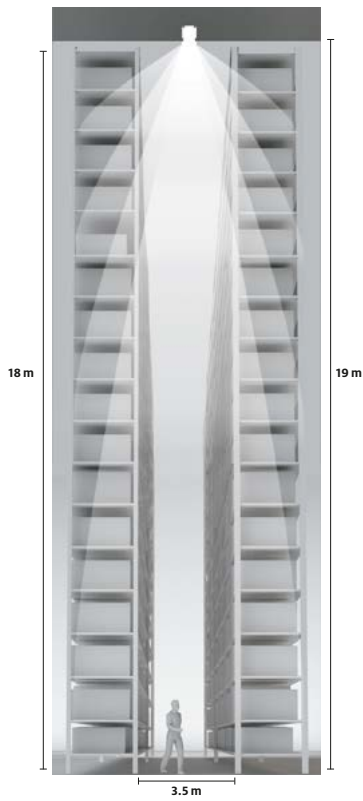

TYPICAL APPLICATIONS

Narrow Beam

- Illuminance levels are optimised for medium to high shelving, emphasis is placed on aisle zones.
- The lighting solution is specifically designed and fitted to match the relevant shelving situation.
- This results in optimised lighting of the aisle zones in question.
- Uniform illumination of shelf surfaces.

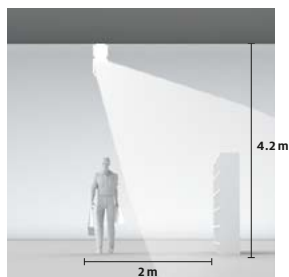

Wallwasher

- Emphasis is placed on high-intensity, uniform illumination of one-sided shelf surfaces.
- The lighting solution is specifically designed and fitted to match the relevant shelving situation.
- An unobtrusive reflector is used to direct customers' attention directly to the shelf surfaces and products that are on display.

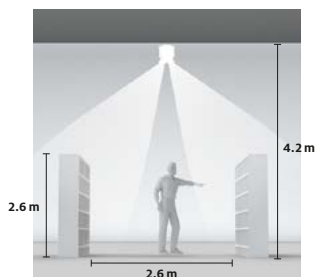

Shelf Beam

- Emphasis is placed on high-intensity, uniform illumination of shelf surfaces.
- The lighting solution is specifically designed and fitted to match the relevant shelving situation.
- This directs customers' attention directly to the shelf surfaces and products that are on display.

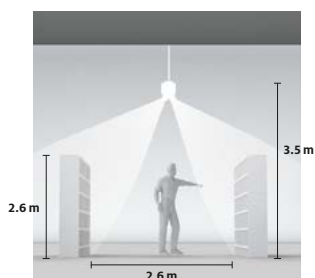

Wide Shelf Beam

- The focus is on the intensive and uniform illumination of the shelving surfaces – for wide aisles or low ceiling heights.
- The lighting solution is planned and installed specifically for the respective shelving situation.
- This draws attention directly to the shelf space and to the product presentation.

Wide Beam

- Emphasis is placed on uniform illumination of manufacturing areas.
- The lighting solution can be designed and deployed regardless of the positioning of the respective machines and production areas.
- This allows subsequent repositioning of machines and production areas – without the need to modify the placement of luminaires.

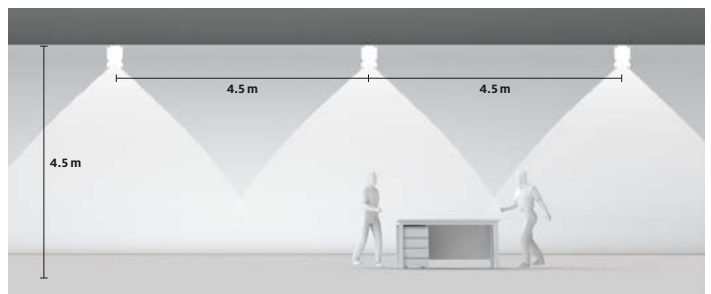

- Emphasis is placed on uniform illumination of aisle zones, shelf surfaces and larger surfaces.
- The lighting solution can be designed and deployed regardless of the positioning of the individual shelves.
- This allows subsequent alteration of the positions of shelves – without the need to modify the placement of luminaires.

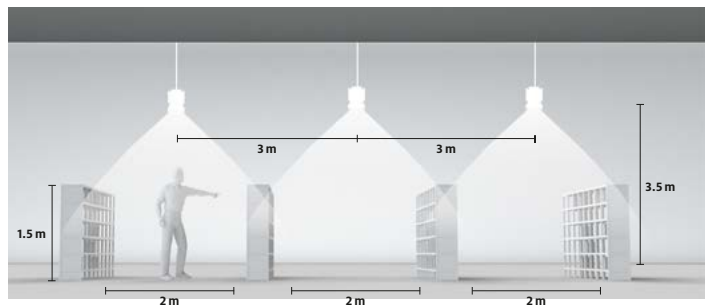

Very Wide Beam

- The focus is on the uniform illumination of surfaces – with a uniquely small number of luminaires that does not affect high planning flexibility or the free arrangement of shelves, machines and production areas.
- Typical application areas in industry are the production areas, in logistics the packing zones and in retail the wide aisles for seasonal and promotional goods.

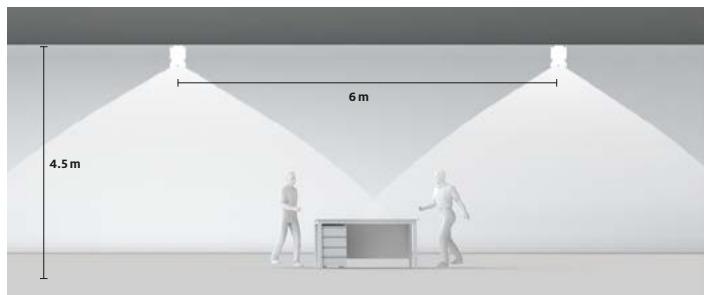

LUMEN PACKAGES

TECTON High Output and Extreme High Output allow for extended luminaire spacings on the continuous-row without reducing the quality or the amount of light, thanks to innovative lighting technology and high lumen packages.

Even the distance between continuous-rows can be significantly increased. In summary, fewer luminaires are required and the investment will pay off over a shorter period of time.

2-metre batten



| | | |
|---------------------|--|--------------------------------|
| High Efficiency | | 7 400 lumens (up to 184 lm/W) |
| High Output | | 10 500 lumens (up to 184 lm/W) |
| Extreme High Output | | 16 000 lumens (up to 154 lm/W) |

1.5-metre batten



| | | |
|---------------------|--|--------------------------------|
| High Efficiency | | 5 500 lumens (up to 184 lm/W) |
| High Output | | 8 000 lumens (up to 182 lm/W) |
| Extreme High Output | | 12 000 lumens (up to 152 lm/W) |

1-metre batten



| | | |
|---------------------|--|-------------------------------|
| High Efficiency | | 3 700 lumens (up to 175 lm/W) |
| High Output | | 5 200 lumens (up to 175 lm/W) |
| Extreme High Output | | 8 000 lumens (up to 145 lm/W) |



DISTINCTIVE FEATURES

95 per cent luminous efficacy even after 11 years

100 000 operating hours, equivalent to around 11.4 years of permanent operation. Even after so much time, the luminous flux and luminous efficacy of the TECTON C will have sunk by only 5 per cent compared with the initial illuminance. The excellent LED service life also has a positive effect on the maintenance factor in the lighting design. This can be set a little higher compared with luminaires with a higher reduction in luminous flux. The result is that the customer requires fewer luminaires in the project and benefits from lower investment and energy costs.

Resistant – even in challenging environments

Whether mechanical or chemical, TECTON C demonstrates impressively high resistance to environmental influences, particularly in an industrial setting. Maximum protection – even in environments containing oil, like those of the metal industry – is guaranteed by the lenses made of impact- and UV-resistant polymethylmethacrylate (PMMA). TECTON C withstands mechanical loads with an extremely high impact protection rating of IK07.

No halogen or silicone

Even extreme conditions have been taken into account in the development of TECTON C. The absence of wiring containing halogen ensures that the amount of toxic fumes is reduced in the event of fire. The silicone-free materials of the device holder also offer optimum conditions for the automotive industry. Painting processes are usually faultless in an environment without paint-wetting impairment substances (PWIS). The independent Fraunhofer Institute has certified TECTON C for PWIS-compliant use.

LED perfection

With a colour rendering index of up to $Ra > 80$ and colour temperatures of 3000 K, 3500 K, 4000 K and 6500 K, TECTON demonstrates its excellent lighting quality

Selection of colours

All components in the TECTON continuous-row system, including accessories, are available in white, silver and black.

As standard: IP50 and IK07 rating

In all optical variants, TECTON continuous-row luminaires dispose of the increased IP50 rating for LEDs and optics. Overlapping lenses and end pieces provide protection against soiling, eliminating cleaning effort and resulting in high IK07 mechanical stability. The thus extended maintenance cycle is very convenient, especially in the case of major exposure to soiling.

Optional control gear

Upon request, TECTON continuous-row luminaires are available with industrial control gear from Tridonic, which offers an extremely long service life of 100 000 hours.

TRIDONIC





ideal for education and office applications
(UGR<19 and L65<3000 cd/m²)

same slim design as the TECTON C continuous-row luminaire

as part of the TECTON product group, as flexible and comfortable to install as usual



TECTON MIREL WITH MIREL LENS OPTIC

TECTON MIREL with MIREL lens optic brings together the best of two worlds. While the slim continuous-row luminaire stands out with its enormous flexibility, the MIREL evolution office luminaire guarantees high visual comfort - even for demanding visual tasks. As a result, this continuous-row system satisfies a wide variety of requirements with a uniform design.

| | |
|---------------------------|---|
| Glare control | UGR<19 and L65<3000 cd/m ² at 4000lm UGR<19 at 5500lm |
| Lumen packages | 4000lm, 5500lm |
| System efficiency | up to 144lm/W |
| Colour temperature | 3000K, 4000K |
| Colour rendering | Ra 80 |
| Service life | 50000h at a reduction in luminous flux to 80% |

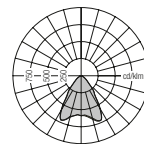

The visible LED lenses combine a directed light distribution with a brilliant appearance. The high lighting quality is manifested on the one hand by the good glare control and on the other in the batwing light distribution and high luminaire efficiency.



TECTON MPO WITH MICRO-PRISMATIC OPTIC

Workplaces for precision assembly laboratories, schools, supermarket check-outs and offices place higher demands on light quality. This is where LED technology can be combined with MPO optics to deliver tangible improvements. Micro-prisms free the 1.5-metre-long TECTON batten luminaires from disturbing reflections caused by visible light points and minimise the subjective glare sensitivity in the application. In this way, the strong light packages of 5500, 6500 and 8000 lumens gain a unique quality. With a colour temperature of

4000 Kelvin, a colour rendering index of Ra 80 and dimmable variants, TECTON with micro-prismatic optics represents a professional solution for specific application requirements. With a higher degree of protection and impact strength, the LED module and MPO optic are also suitable for industrial environments.

Design TECTON MPO with micro-prismatic optics: Zumtobel

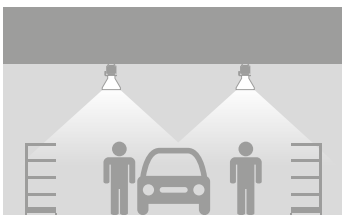

Non-reflective light for demanding workplaces in industry, for example, production lines for cars.

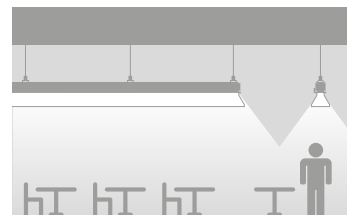

High-quality light and a comfortable atmosphere are rewarded in classrooms, for example, with a better ability to concentrate.



TECTON BASIC WITH DIFFUSER OPTIC

TECTON BASIC with a diffuser optic was especially developed for locations with reduced requirements, enabling Zumtobel LED technology to be used in areas that previously had to make do with conventional solutions. As an LED batten luminaire that has been simplified in terms of both technology and optics, TECTON BASIC delivers a luminous flux of more than 8000 lm and an efficiency of around 140 lm/W, making it especially suitable for less complex lighting tasks in industry and retail. The luminaire is based on the tried-and-tested TECTON trunking, which ensures easy installation, flexible use and virtually unlimited options when it comes to upgrading.

TECTON BASIC 1.5 metre

High Efficiency



High Output

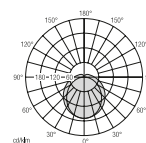

With its Lambertian beam characteristics, the TECTON BASIC light bar is ideal for use in rooms with low ceiling heights.



LUMINAIRES FOR INDUSTRIAL APPLICATIONS



A major advantage of the CRAFT II industrial luminaire is its simple and uncomplicated installation on the TECTON trunking.

Combining lighting solutions with TECTON keeps them flexible in the long term. Luminaires that have already been installed can be moved easily, and additional luminaires can simply be clicked into place where desired.

CRAFT II

A powerhouse for TECTON. High lumen packages in a continuous-row lighting system with protection against dust and spray water. The CRAFT II offers a powerful, extremely durable high-bay luminaire as an installation variant for the TECTON system.



zumtobel.com/craft2

PERLUCE

This moisture-proof luminaire combines protection classes IP50 and IP54 with a wide variety of optics and various shapes. (Protection class for entire continuous-row: IP20)



zumtobel.com/perluce

AMPHIBIA

The IP66 protection class luminaire meets even the most stringent industry targets: it is stable, dirt-repellent and illuminates rooms very evenly. (Protection class for entire continuous-row: IP20)



zumtobel.com/amphibia



ACCENT LIGHTING



By allowing integration of Zumtobel's INTRO and VIVO II spotlight ranges, as well as the PANOS infinity pendant luminaire, the TECTON continuous-row lighting system is able to create impressive lighting accents while fulfilling all other tasks as well. Thus, the lighting requirements for shops and retail spaces – ranging from uniform illumination to impressive lighting effects using high-precision reflectors – can be mastered with high efficiency. Here, too, installation is considerably facilitated by CLIX and plug-and-play mechanisms.



PANOS infinity
pendant luminaire

zumtobel.com/panos



INTRO
spotlights

zumtobel.com/intro



VIVO II
spotlights

zumtobel.com/vivo2



LUMINAIRES FOR OFFICE APPLICATIONS



Complete office luminaires really demonstrate the advantages of TECTON mounting. Both the trunking and the luminaires are optimised for the integration of emergency lighting and lighting controls.

ECOOS II

This office luminaire is based on a combination of micro-pyramidal optic and diffuser-pearl covering with a 360-degree light distribution.



zumtobel.com/ecoos

MELLOW LIGHT evolution/infinity

Taking inspiration from nature, MELLOW LIGHT creates pleasantly bright spaces with little shadowing.



zumtobel.com/ml

LINCOR

Thanks to the balanced mixture of direct and indirect light, this narrow light line promises perfect visual comfort for office workplaces.



zumtobel.com/lincor

EMERGENCY LIGHTING

EMERGENCY LIGHTING RESCLITE PRO

RESCLITE PRO offers the optimal solution for every application: compact and highly efficient emergency lighting that can be fully integrated into the TECTON continuous-row system without the need for tools.

RESCLITE PRO escape

Even long escape routes can be illuminated with just a few luminaires. The unique escape 90° optics aim the beam of light around the corner. This makes it possible to illuminate two right-angled intersecting corridors with a single emergency luminaire.

RESCLITE PRO antipanic

The wide-area illumination ensures good orientation in the room and helps minimise panic in an emergency – with a minimum number of luminaires.

RESCLITE PRO spot

In an emergency, a focused beam highlights essential objects, such as fire extinguishers.

RESCLITE PRO high ceiling

With escape-route and anti-panic lighting optimised for high rooms, even large halls can be ideally prepared for emergencies.

RESCLITE PRO high performance

The HP (high performance) version even allows luminaire spacing of up to 38 metres.

zumtobel.com/resclite

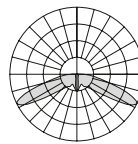

escape

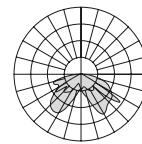

escape 90°

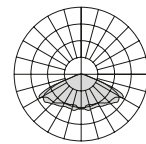

antipanic

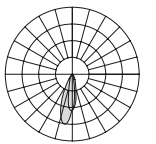

spot



The RESCLITE PRO app provides a step-by-step guide to the planning and selection of emergency luminaires.

resclitewebapp.zumtobel.com



ESCAPE-SIGN LUMINAIRES

Even escape-sign luminaires can be perfectly integrated into the system via the TECTON trunking. This guarantees a high degree of efficiency and maximum safety in an emergency – and of course low installation effort.

PURESIGN 150

This slim luminaire conceals the most modern LED and lighting technology, which backlights the pictogram with optimum uniformity.

CROSSIGN 110/160

These all-round luminaires are ready to cope with the kind of tough ambient conditions often found in industry applications. The IP42-protected and IP54-protected luminaires are resistant against dirt and moisture.*

ECOSIGN 160

This all-rounder of the Zumtobel escape-sign luminaires combines many practical qualities in a single luminaire. Whether in industrial warehouses or car parks – the ECOSIGN is well equipped for any application thanks to an IP65 degree of protection and a detection range of 32 metres. Maintenance is tool-free.*

*Protection class for entire continuous row: IP20



zumtobel.com/puresign



zumtobel.com/crossign



zumtobel.com/ecosign



The web app for escape-sign luminaires simplifies both the planning and the selection of emergency solutions.
signwebapp.zumtobel.com

INTEGRATION OF TECTON

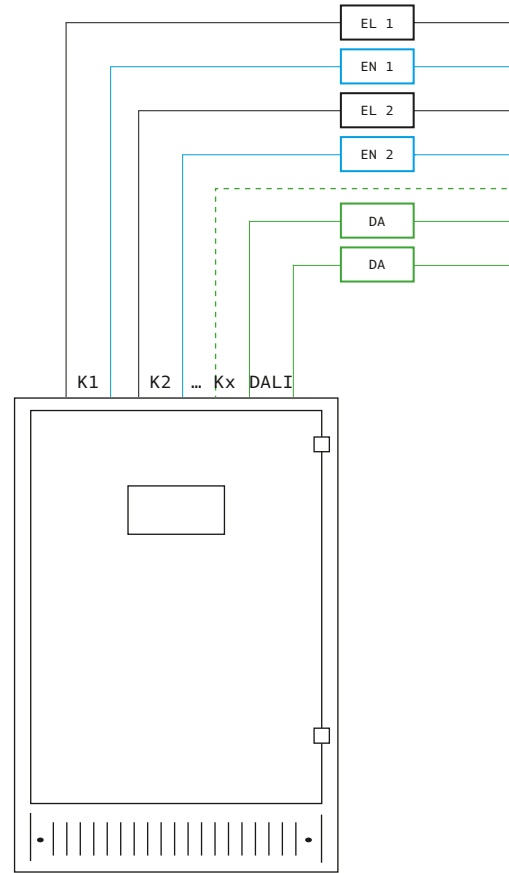
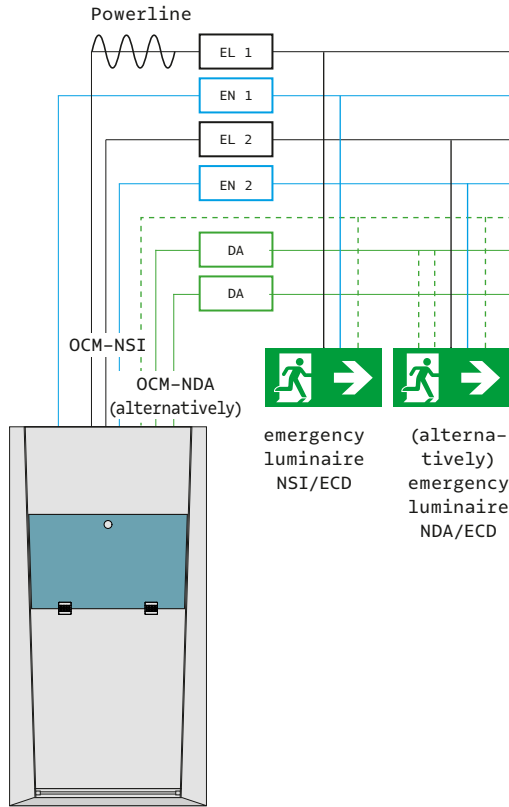
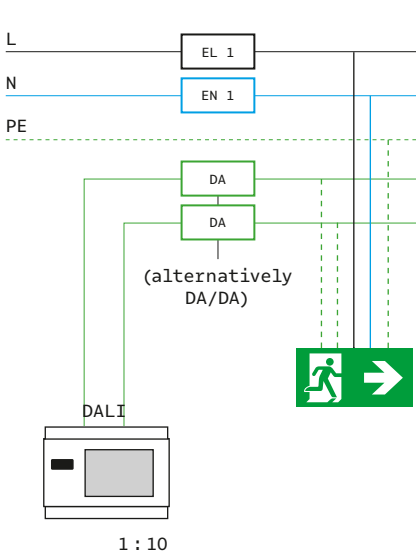

Function tests and annual system tests are performed automatically. The system is centrally monitored where an SB128 Controller is used.

**SB 128
Single battery controller**

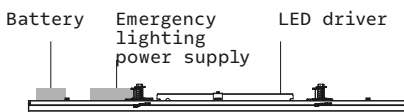

**eBox
Central battery system**

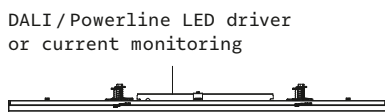

**CPS
Central battery system**

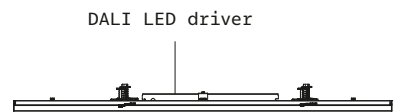

Self-contained battery supply

In the case of self contained luminaires, the battery is fitted in the actual luminaire. Such luminaires operate as completely self-contained units and are easy to install. There is no need for expensive structural measures or fire-resistant wiring accessories. Self contained luminaires are rated E1D or E3D depending on whether they provide 1 hour or 3 hours of operating time.

eBox – Central battery system

The centrally supplied emergency lighting system is perfectly adjusted to the specifics of LED luminaires and features double energy efficiency: if energy-saving luminaires are connected, eBox scores high on low system output. The emergency lighting system supplies luminaires with a total installed load of 1500 W with power for one hour, luminaires with a total of 500 W for three hours. Several systems can be linked quite easily.

CPS – Central battery system

Based on a modular system, each central battery system is perfectly customised to the client's requirements. The central battery system communicates via DALI. This way, each DALI luminaire can be used as a separately monitored emergency luminaire and be individually controlled. Other benefits include minimal maintenance effort and interference-free data communication.

zumtobel.com/central

zumtobel.com/ebox



emergency luminaire
NDA/ECD

**Escape-sign luminaires with
TECTON adapter**

Every escape-sign luminaire is available as a self-contained group battery or centrally powered version.

**Increased safety with four
circuits**

Two independent circuits for emergency lighting (4x1.5mm²)

**MONITORING AND SUPPLY SYSTEMS:
SYSTEM STATUS AT A GLANCE**

In order to operate safety-relevant lighting independently from the general power supply, Zumtobel provides self-contained emergency luminaires with integrated battery or central battery luminaires. Knowing that everything will function reliably in an emergency is invaluable. All TECTON emergency luminaires can be addressed, configured and tested via the emergency lighting system. In industrial halls with high temperatures, central systems such as the nBox, eBox or CPS are particularly suitable because the batteries are not exposed to the high temperatures in these industrial spaces and the maintenance of the luminaires is reduced to a minimum.

LIGHTING MANAGEMENT



MSENS MC Multisensor

SENSORS

Motion and presence sensors can reduce power consumption by 20 to 40 per cent by dimming/brightening or switching off the lighting, depending on presence. Options include the motion sensor TECTON PST, the presence detector ED-SENS and the motion and daylight sensor MSENS. Daylight sensors dim/brighten the luminaires depending on incident natural daylight. The look-out sensor ED-EYE or the motion and daylight sensors MSENS are TECTON-compatible.



| | ED-SENS | ED-EYE | PST | MSENS-MC | MSENS-HC |
|-----------------------------------|-------------------------------|-----------------------------------|---------------------------------------|--|-----------|
| Sensor type and function | Presence sensor Presence | Daylight sensor Incident light | Motion sensor Corridor function | Multisensor Motion and ambient light | |
| Sensor: Standalone | ED-SENS | | PST | MSENS BMLINK MC | |
| Sensor: System | ED-SENS | ED-EYE | PST-DIMLITE Master/Slave ED-PST | Wireless: MSENS BMLINK MC Wired: MSENS MC | |
| Lighting management system | LITECOM LITENET DIMLITE | LITECOM LITENET DIMLITE | DIMLITE LITECOM LITENET | DALI-V2 systems bmlINK | |
| Mounting height | up to 3.5m | any | up to 16m | up to 8m | up to 16m |

CONTROL LIGHT WIRELESSLY

Complicated, costly or simply not yet complete? In refurbishment projects without a control line, bmLINK offers an elegant – wireless – solution to installation problems. The bmLINK module allows TECTON luminaires to be wirelessly integrated in DALI lighting control systems. The transition from a switchable TECTON system with conventional light sources to a dimmable TECTON solution is therefore made easy.

bmLINK for wireless DALI connection

Cable-free, low-effort but still fully DALI-compatible: bmLINK wireless connects continuous rows that are difficult to integrate with conventional cables into existing or new DALI systems. Upgrading a non-dimmable solution to a completely dimmable one could not be easier, because even order picking is wireless via mobile devices.



TECTON bmLINK
Transmitter/recipient

zumtobel.com/bmlink

INTEGRATION OF TECTON

Manage light efficiently and save costs

Lighting management systems such as LITENET or LITECOM help you get the most out of daylight and achieve maximum lighting comfort and quality using minimal energy, materials and time. One example of how additional energy can be saved is through the use of predefined switch-on times, which ensure that the lighting is only on when it's really needed. Runtimes can be programmed via the central building calendar.

PLUG & PLAY LIGHTING MANAGEMENT

DIMLITE

DIMLITE is a simple lighting management system, which nevertheless features the most important convenience and energy-saving functions and is ideal for small applications involving up to 100 DALI luminaires.

zumtobel.com/dimlite

System limitations:

- 25 DALI- or 50 DSI luminaires per channel

Energy saving:

- Uses indoor sensor to take daylight into account
- Presence detectors
- No-load disconnection of electronic ballasts by relay switching

Initial operation:

- Auto setup requires relatively little commissioning effort

Add-on functions:

- User-configurable lighting scenes
- CIRCLE control point and conventional momentary-action switches
- Switches

TECTON groups

1-4 (max. 25 x DALI- or 50 x DSI luminaires per channel - can be extended by DALI-V or DSI-V)

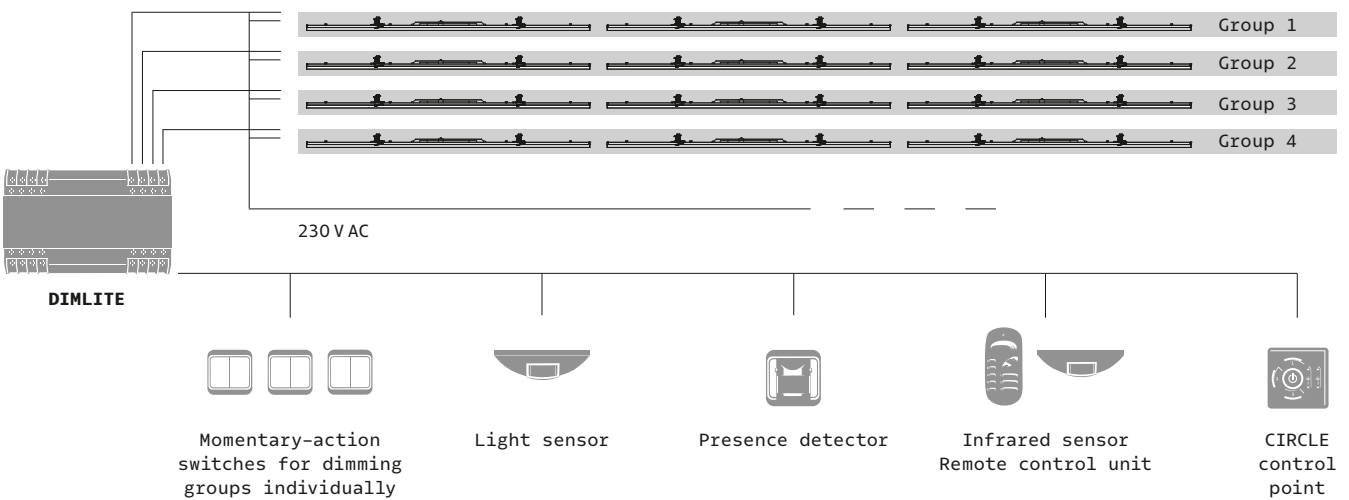

LIGHTING MANAGEMENT FOR LUMINAIRES, BLINDS AND EMERGENCY LIGHTING

LITECOM

The scalable LITECOM system offers customised state-of-the-art bus technology for any size of installation. Lighting system and blinds are controlled on the basis of the current lighting and weather conditions. Energy consumption is sustainably optimised through daylight-based management, central time settings and presence detectors. LITECOM is suitable for installations with a medium number of DALI luminaires and blinds.

zumtobel.com/litecom

System limitations:

- max. 250 addresses per LITECOM CCD

Energy saving:

- Uses indoor light sensor to take account of daylight
- Automatic control of blinds
- Presence detectors
- Flexible calendar and timer functions

Initial operation:

- Commissioning via Zumtobel Service staff or wizard software

Emergency lighting integration:

- eBox

Add-on functions:

- User-configurable lighting scenes
- Various local control options (CIRIA, CIRCLE, EnOcean radio etc.)
- Graphic user interface
- Touch panel integration
- Optional remote maintenance

LITENET

For installations with more than 250 addresses, the LITENET lighting management system must be use

zumtobel.com/litenet

System limitations:

- Up to 500 "Economy topology" automation addresses
- Up to 2000 "Compact topology" automation addresses
- Up to 10000 "Flexible topology" automation addresses

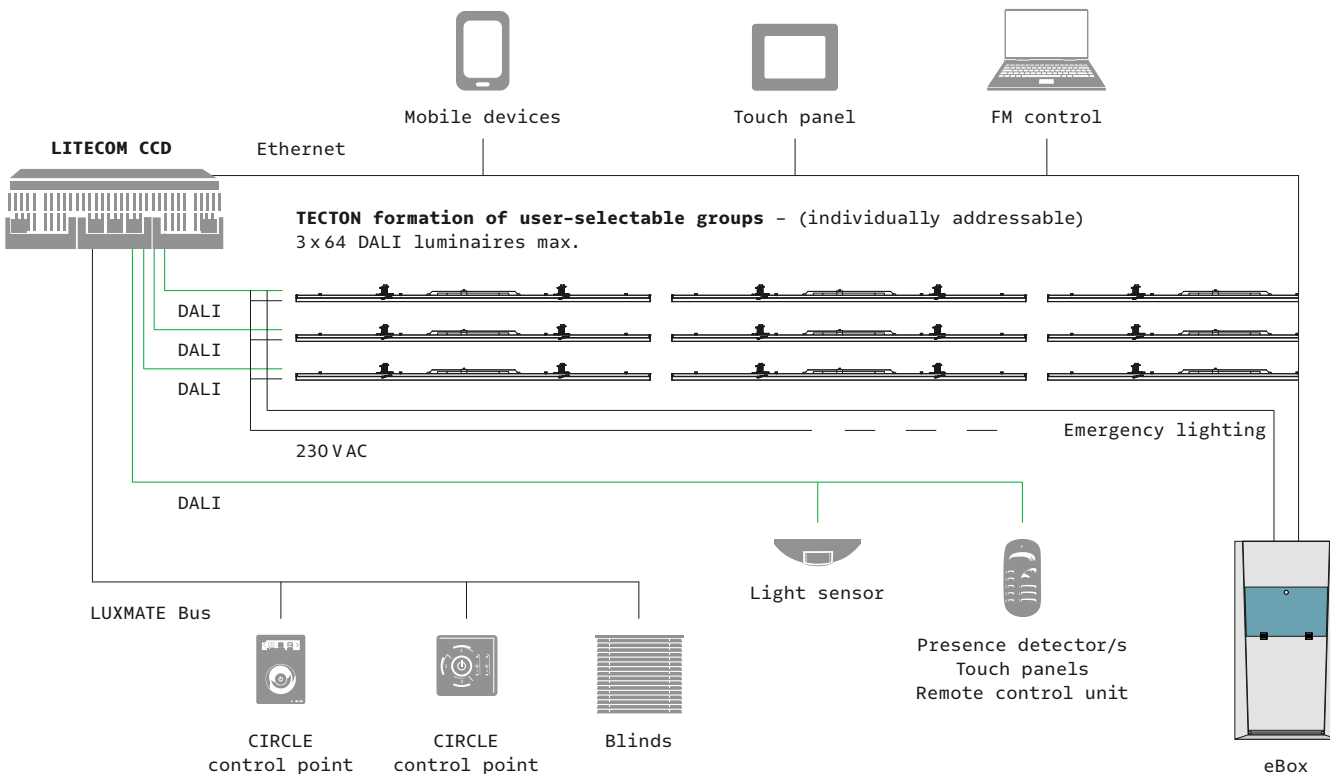

SAVE TIME AND MONEY WITH TECTON

In a test organised to measure the installation time of eight different continuous-row systems (with a length of 15 metres), independent refaconsult GmbH found that TECTON can be installed considerably faster than comparable products. Time savings of up to 55 per cent certainly save a lot of money. Compared to conventional T16

solutions, 61 per cent of time can be saved on average with a TECTON solution. Moreover, TECTON already integrates emergency lighting circuits and DALI control lines.

15 m continuous-row system

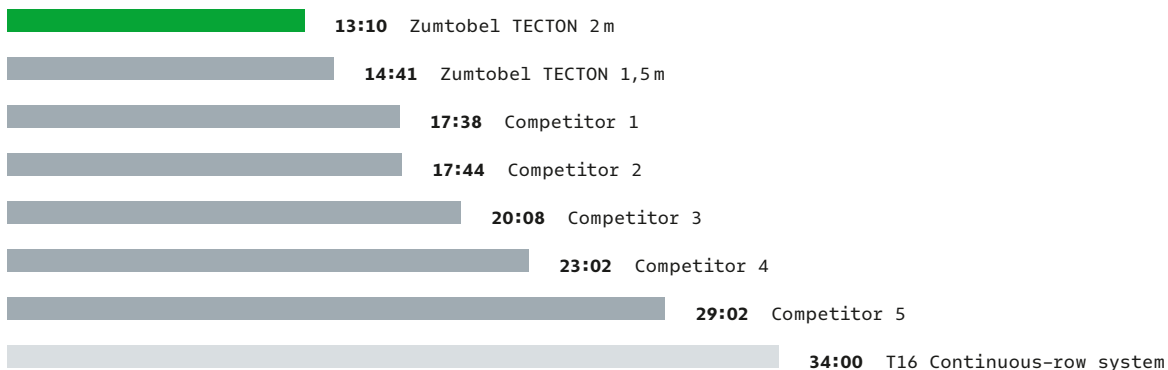
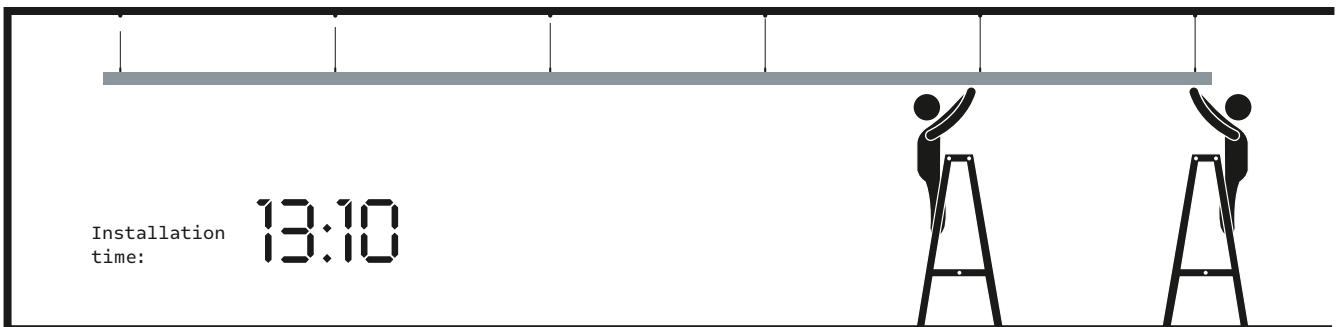













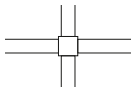

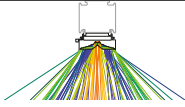
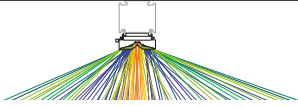



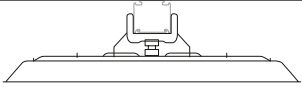
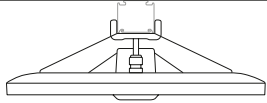

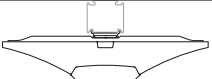
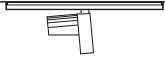
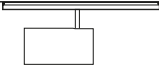
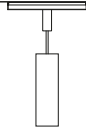

Framework conditions test setup:

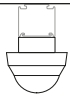
Length of continuous-row 15m, ceiling height 3.7m, height of continuous-row 3.2m, 2 persons with ladders. The time indicated is for mounting excluding unpacking and excl. assembly of suspension systems (approx. 30min).



TECTON IP20 SYSTEM OVERVIEW

| | | | |
|---------------------------------|--|--|---|
| SUSPENSION |  Ceiling |  Caddy Clip |  Wall |
| TRUNKING |  Electric feed |  Trunking |  Node connector |
| CONTINUOUS-ROW LUMINAIRE |  TECTON C |  Wide Beam |  Very Wide Beam |
| |  TECTON MPO |  TECTON BASIC |  TECTON MIREL |
| INDUSTRIAL LUMINAIRES |  CRAFT II performance | |  CRAFT II plus |
| OFFICE LUMINAIRES |  LINCOR |  ECOOS II |  MELLOW LIGHT |
| SPOTLIGHTS |  INTRO |  VIVO II |  PANOS infinity pendant |
| EMERGENCY LIGHTING |  RESCLITE PRO |  CROSSIGN |  ECOSIGN |
| LIGHTING MANAGEMENT |  PST |  MSENS MC/HC |  bmLINK |
| ACCESSORIES |  Glare Control mounting optics |  Cable duct |  Strain relief |

PRODUCT RANGE TECTON



Chain



Cord



TECTON continuous-row system and components



Individual trunking



Narrow Beam



Shelf Beam

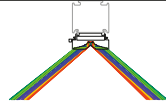

Wide Shelf Beam



Wallwasher



AMPHIBIA



PERLUCE

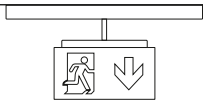

PURESIGN



ED-EYE



ED-SENS

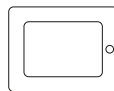

LITECOM



DIMLITE pro



Socket element



Plastic cover

TECTON IP64/IP54



















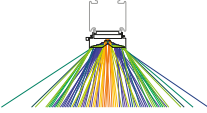
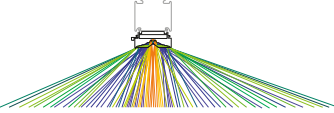

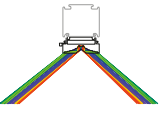

IP – two letters, one promise: TECTON IP64/IP54 makes the advantages of the tried-and-tested continuous-row lighting system available for demanding industrial environments. The dust-proof and splashwater-proof TECTON IP64/IP54 variant can be used wherever metal, wood or paper is processed, food is kept cool, or car parks are

lit. Quick, tool-free installation. 100% flexible – can be fitted with general lighting, safety lighting and lighting management. With Zumtobel Services if required: from project design to installation and maintenance, we offer support throughout the entire life cycle of a lighting solution.

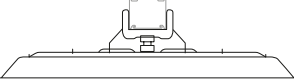
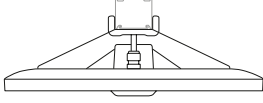

Whether in joiner's workshops or in cold warehouses:
The TECTON IP64/IP54 system is reliably protected against
the ingress of foreign bodies and splash water.
Optimal for use in dusty or humid environments.

TECTON IP64/IP54 SYSTEM OVERVIEW

| | | | | | |
|------|---|--|---|--|--|
| IP64 | SUSPENSION |  Ceiling |  Wall |  Chain |  Cord |
| | TRUNKING |  Electric feed |  Trunking |  Individual trunking | |
| | CONTINUOUS-ROW LUMINAIRE |  TECTON C | | | |
| | Light distribution |  Wide Beam |  Very Wide Beam |  Narrow Beam | |
| | |  Shelf Beam |  Wide Shelf Beam |  Wallwasher | |
| | ACCESSORIES |  Glare Control mounting optics |  Cable grip |  Strain relief |  Plastic cover |
| |  CRAFT II performance | |  CRAFT II plus | | |
| IP54 | EMERGENCY LIGHTING |  CROSSIGN |  RESCLITE PRO | | |
| | LIGHTING MANAGEMENT |  PST |  MSENS MC/HC |  bmLINK |  DIMLITE pro |



Sorting office Härkingen | CH



Typico, Lochau | AT

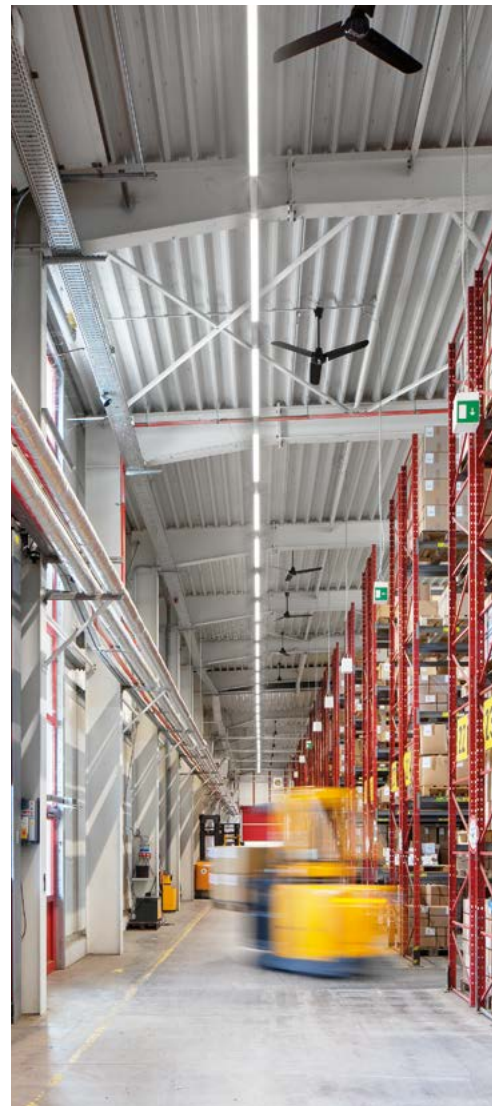

Oskar Lehmann, Blomberg | DE

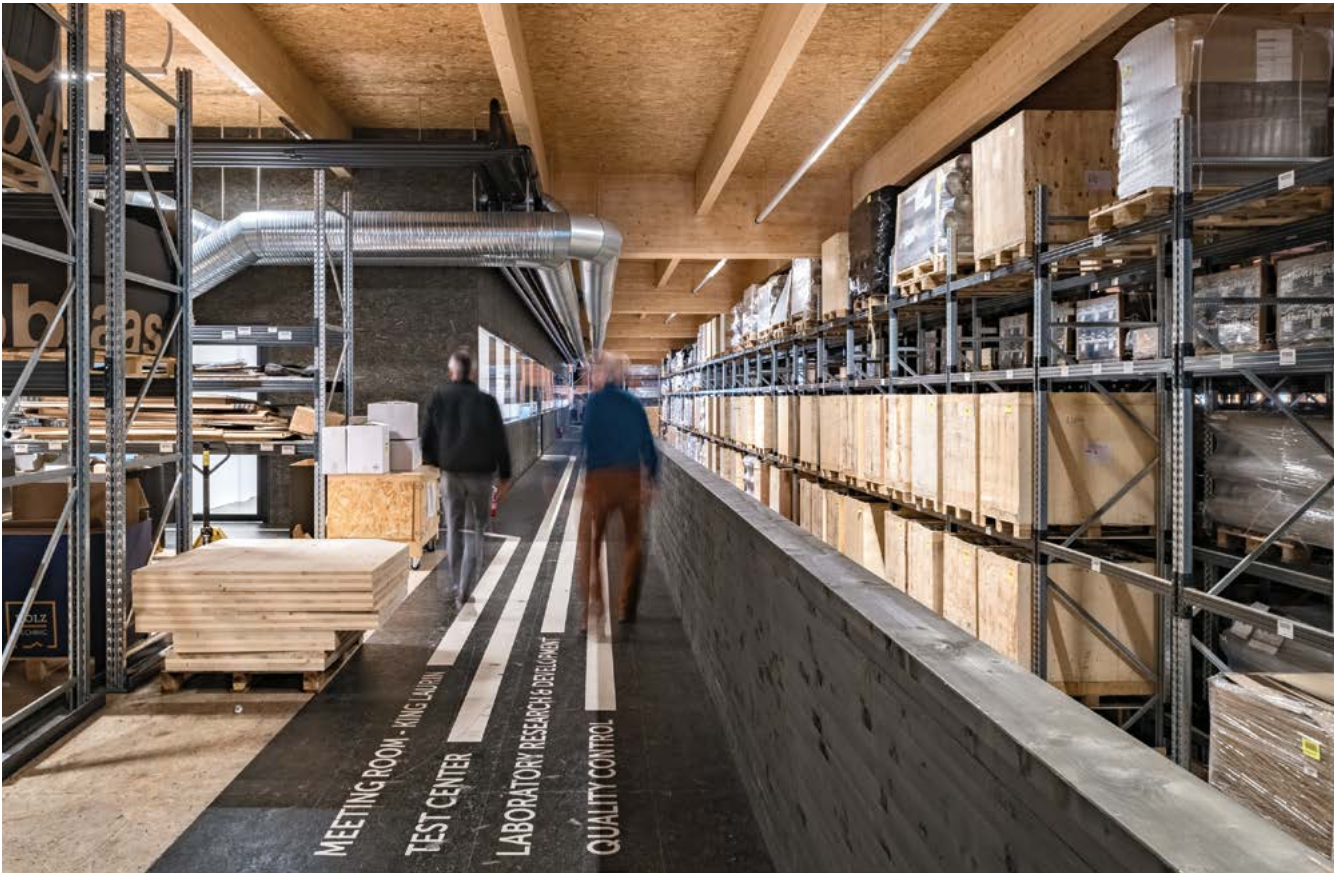

Rothoblaas, Kurtatsch | IT



Weiler Möbel | AT



Serioplast, Bergamo | IT



Lincoln Medical School University of Lincoln | UK



Elli Markt, Delbrueck | DE



Eurospar Schwefel, Dornbirn | AT



Audi Terminal Wichert, Hamburg | DE

T H E L I G H T



zumtobel.com/contact